

EcoCivil retains the copyright in all intellectual property, including designs and/or documents prepared in terms of this appointment for the project covered by the appointment. The client may use the designs and/or documents for the sole purpose of their intended use on this project only subject to payment for the design having been received. Use for any other purpose, whether or not the design and/or documents have been paid for constitutes an infringement of copyright, and all rights are reserved.

All dimensions to be checked on site before any work is put in hand. Refer any discrepancies to the engineer.
Copyright reserved

DATE	REVISION	BY
17/05/2019	4	CONTAMINATED WATER MAN.
02/05/2019	3	STOCKPILE AREAS CHANGED
23/01/2019	2	ELECTRICAL CONNECTION



1365 LAWSON AVENUE
WAVERLEY, 0186
TEL: +27 (0)82 774 4412
FAX: +27 (0)86 460 7150

ENGINEER _____ DATE _____

CLIENT _____ DATE _____

DESIGNED	DRAWN	TRACED	APPROVED
PDC	PDC		

CLIENT
GARDEN ROUTE DISTRICT MUNICIPALITY

PROJECT
GARDEN ROUTE WASTE MANAGEMENT FACILITY

DRAWING DESCRIPTION
GENERAL LAYOUT PLAN

SCALE 1:5000 DATE NOV 2018

DRAWING NUMBER 18-0007-101 REVISION 4

CLIENT'S DRAWING NUMBER

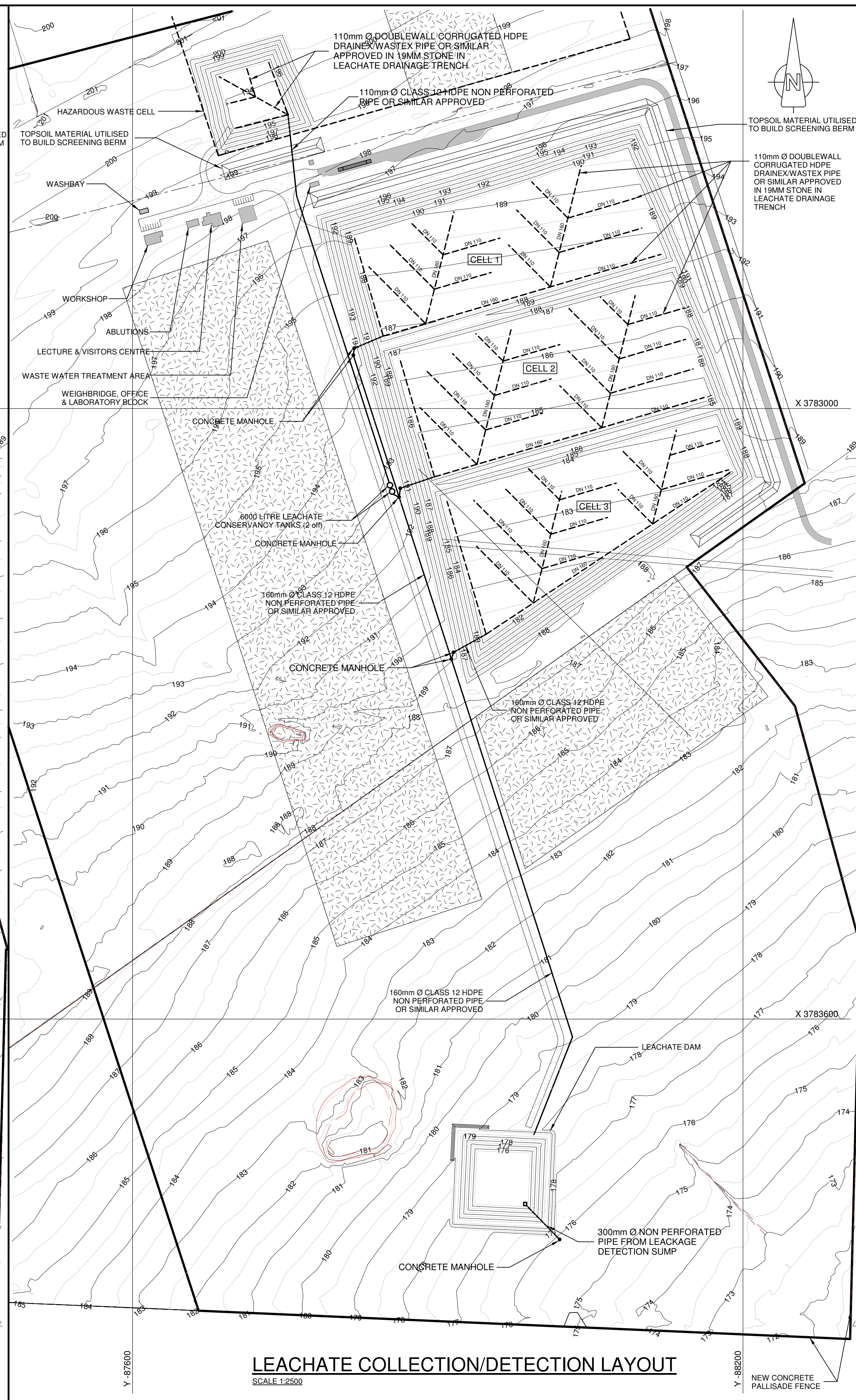
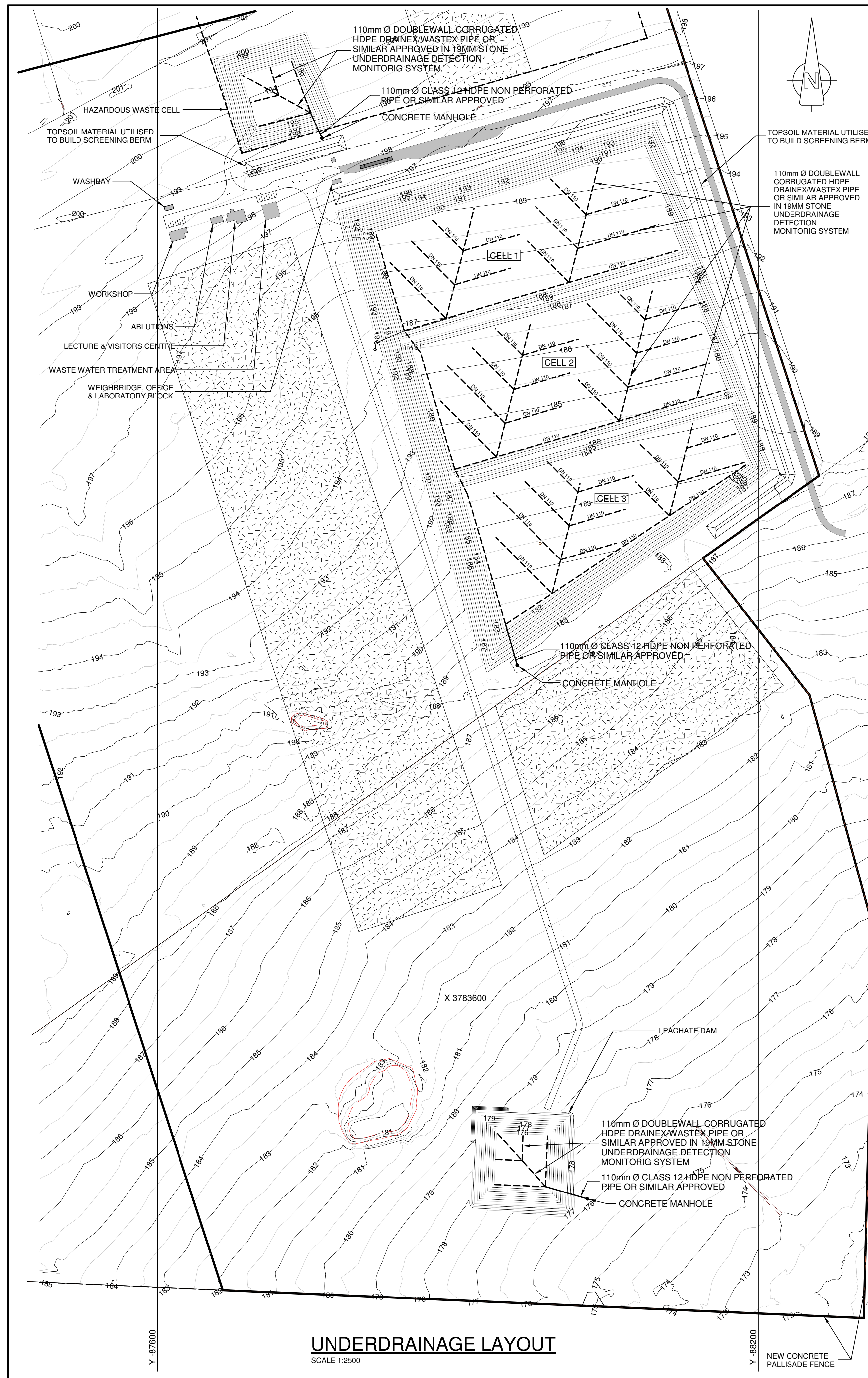

EcoCivil retains the copyright in all intellectual property, including designs and/or documents prepared in terms of this appointment for the project covered by the appointment. The client may use the designs and/or documents for the sole purpose of their intended use on this project only subject to payment for the design having been received. Use for any other purpose, whether or not the design and/or documents have been paid for constitutes an infringement of copyright, and all rights are reserved.

All dimensions to be checked on site before any work is put in hand. Refer any discrepancies to the engineer.

Copyright reserved

10/05/2019	2	PIPEWORK UPDATED	PDC
DATE	REVISION	BY	

EcoCivil
Consulting Engineers

1365 LAWSON AVENUE
WAVERLEY, 0186

TEL: +27 (0)82 774 4412
FAX: +27 (0)86 460 7150

ENGINEER _____ DATE _____

CLIENT _____ DATE _____

DESIGNED	DRAWN	TRACED	APPROVED
PDC	PDC		

CLIENT
GARDEN ROUTE DISTRICT MUNICIPALITY

PROJECT
GARDEN ROUTE WASTE MANAGEMENT FACILITY

DRAWING DESCRIPTION
UNDERDRAINAGE & LEACHATE MANAGEMENT PLAN

SCALE	DATE
1:2500	NOV 2018

DRAWING NUMBER	REVISION
18-0007-102	2

CLIENT'S DRAWING NUMBER

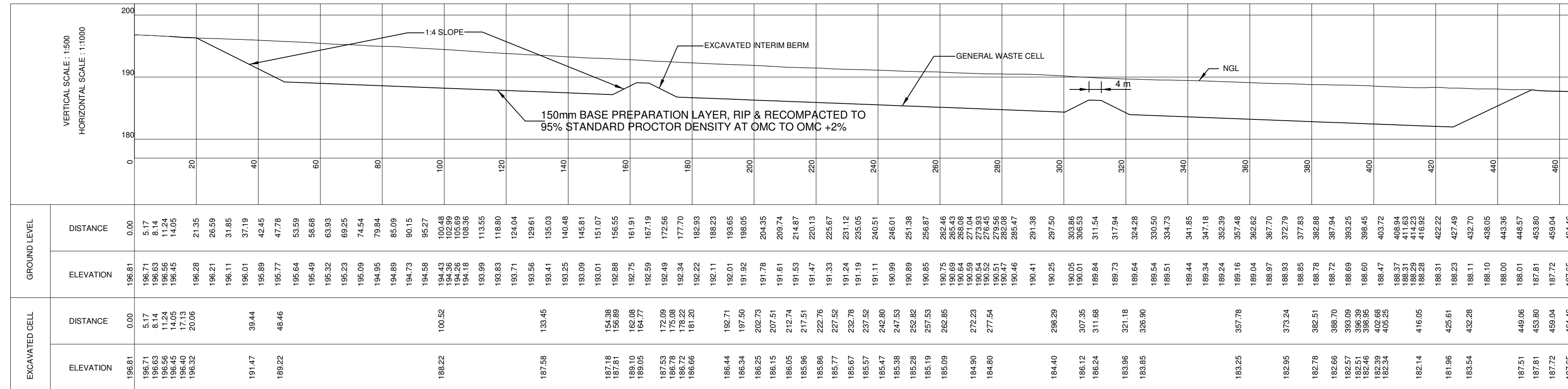

TYPICAL SECTION THROUGH GENERAL WASTE CELL

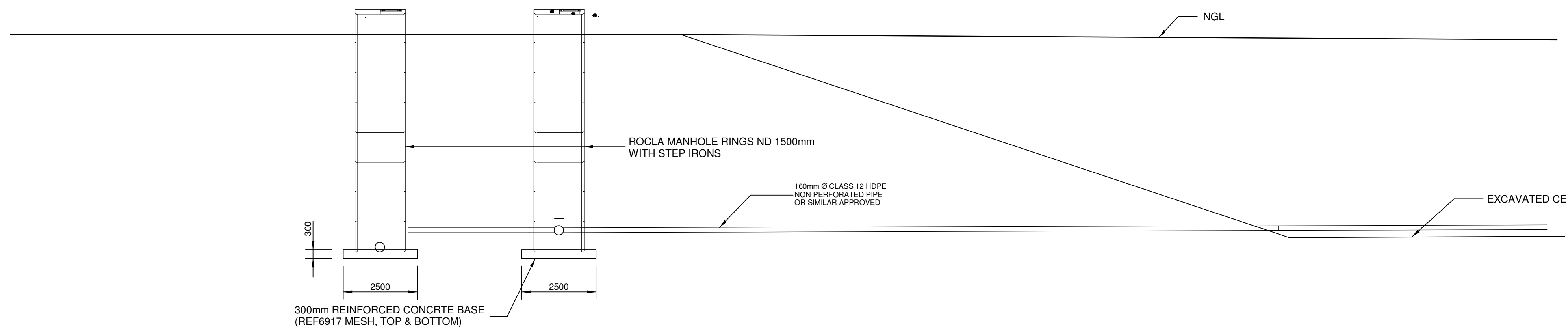

TYPICAL LEACHATE VALVE AND COLLECTION MANHOLE DETAIL

SCALE 1:100

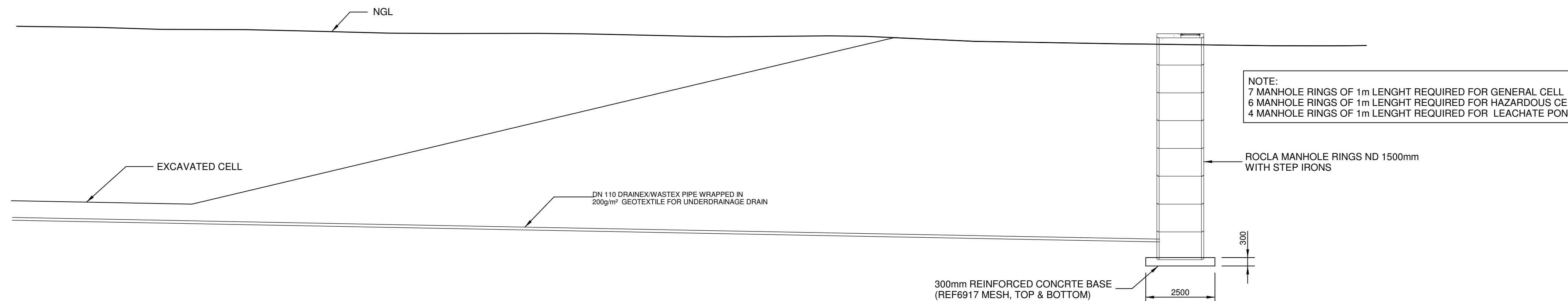

TYPICAL UNDERDRAINAGE MANHOLE DETAIL

SCALE 1:100

EcoCivil retains the copyright in all intellectual property, including designs and/or documents prepared in terms of this appointment for the project covered by the appointment. The client may use the designs and/or documents for the sole purpose of their intended use on this project only subject to payment for the design having been received. Use for any other purpose, whether or not the design and/or documents have been paid for constitutes an infringement of copyright, and all rights are reserved.

All dimensions to be checked on site before any work is put in hand. Refer any discrepancies to the engineer. Copyright reserved

10/05/2019	2	LEACHATE MANHOLE DETAIL	PDC
DATE	REVISION	BY	

EcoCivil
Consulting Engineers

1365 LAWSON AVENUE
WAVERLEY, 0186

TEL: +27 (0)82 774 4412
FAX: +27 (0)86 460 7150

ENGINEER _____ DATE _____

CLIENT _____ DATE _____

DESIGNED	DRAWN	TRACED	APPROVED
PDC	PDC		

CLIENT
GARDEN ROUTE DISTRICT MUNICIPALITY

PROJECT
GARDEN ROUTE WASTE MANAGEMENT FACILITY

DRAWING DESCRIPTION
SECTION AND DETAILS

SCALE 1:2500 DATE NOV 2018

DRAWING NUMBER 18-0007-103 REVISION 2

CLIENT'S DRAWING NUMBER

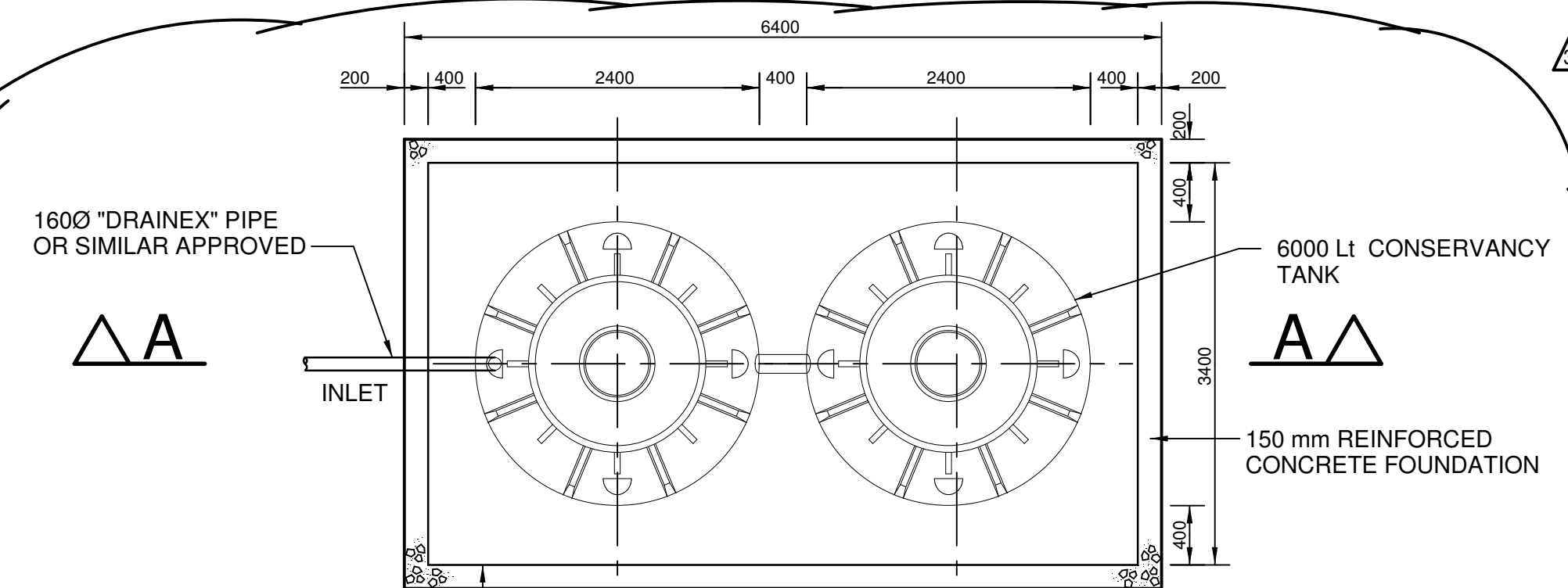

PLAN VIEW
SCALE 1:50

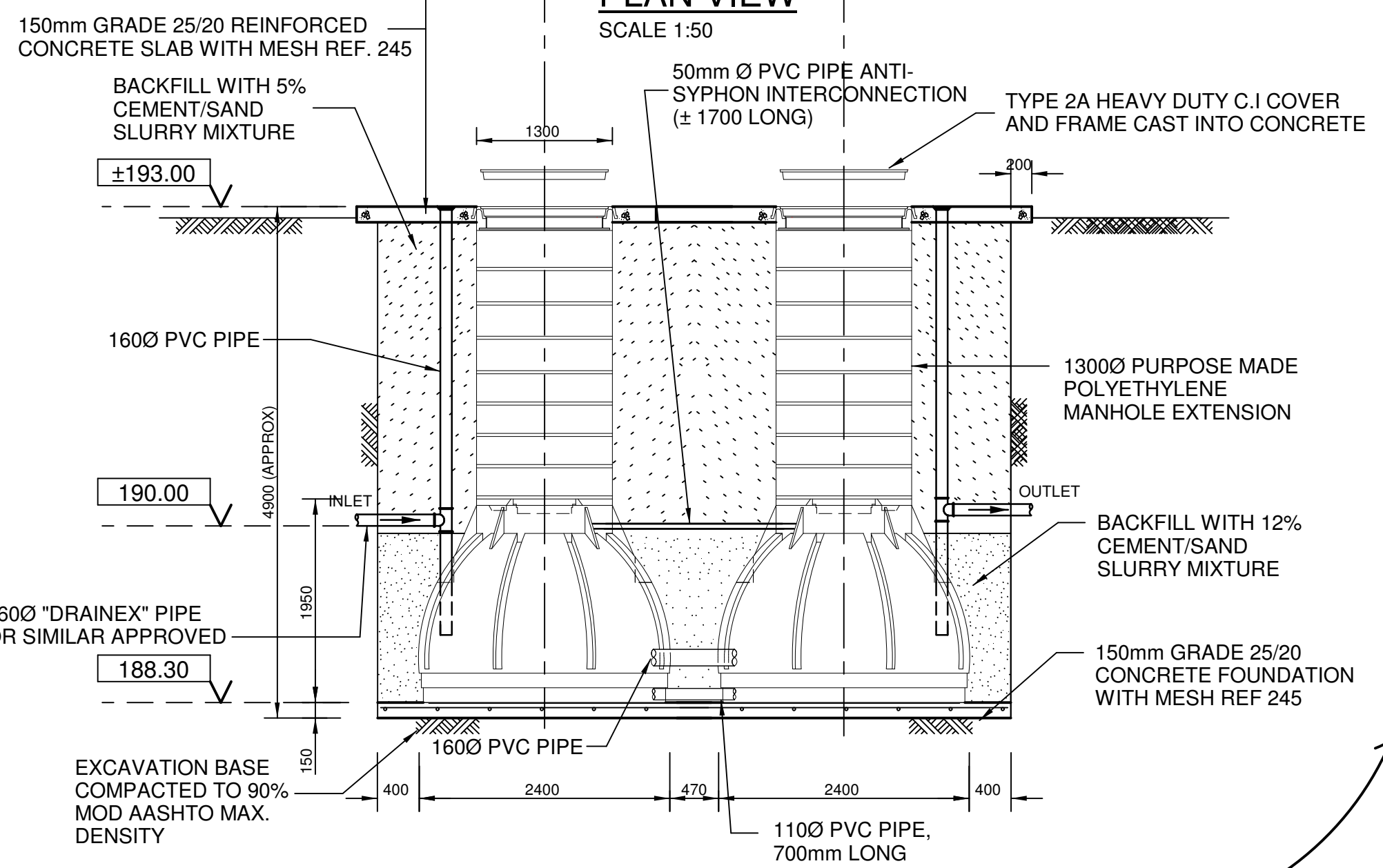

SECTION A-A 6000 LITRE LEACHATE CONSERVANCY TANKS (2 off)
SCALE 1:50

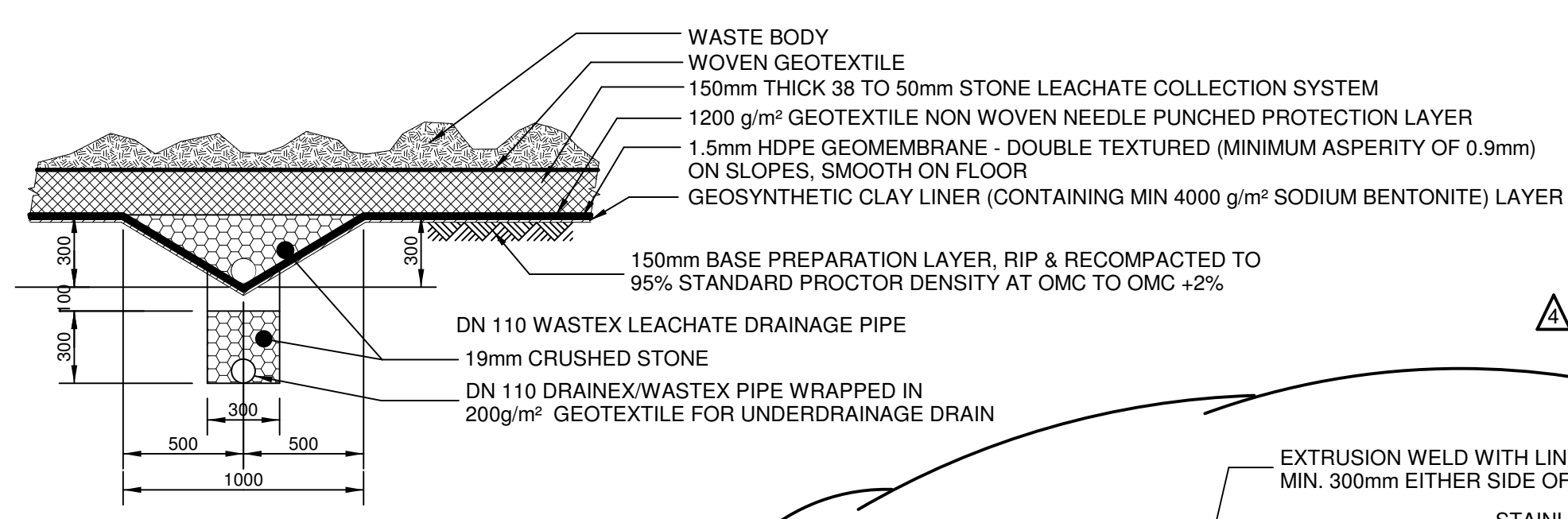

LEACHATE COLLECTION AND UNDERSRAINAGE DETAIL
SCALE 1:25

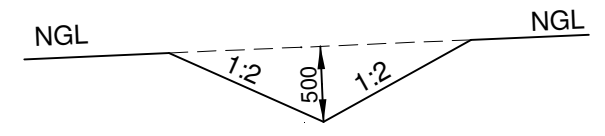

TYPICAL STORM WATER V-DRAIN DETAIL
SCALE 1:50

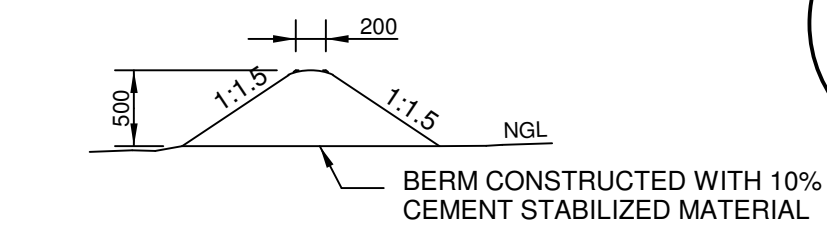

TYPICAL STORM WATER CONTROL BERM
SCALE 1:50

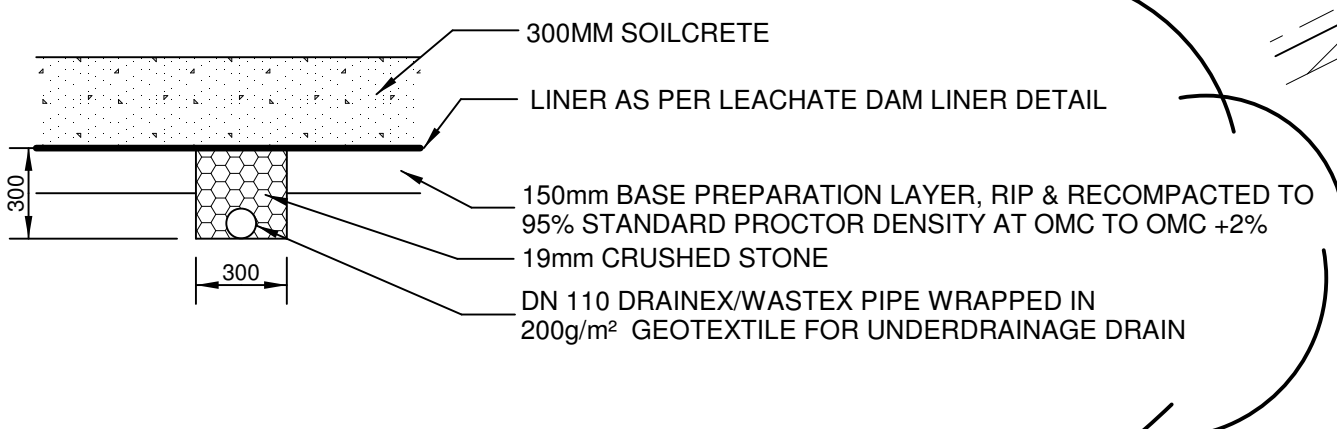

LEACHATE DAM UNDERSRAINAGE DETAIL
SCALE 1:25

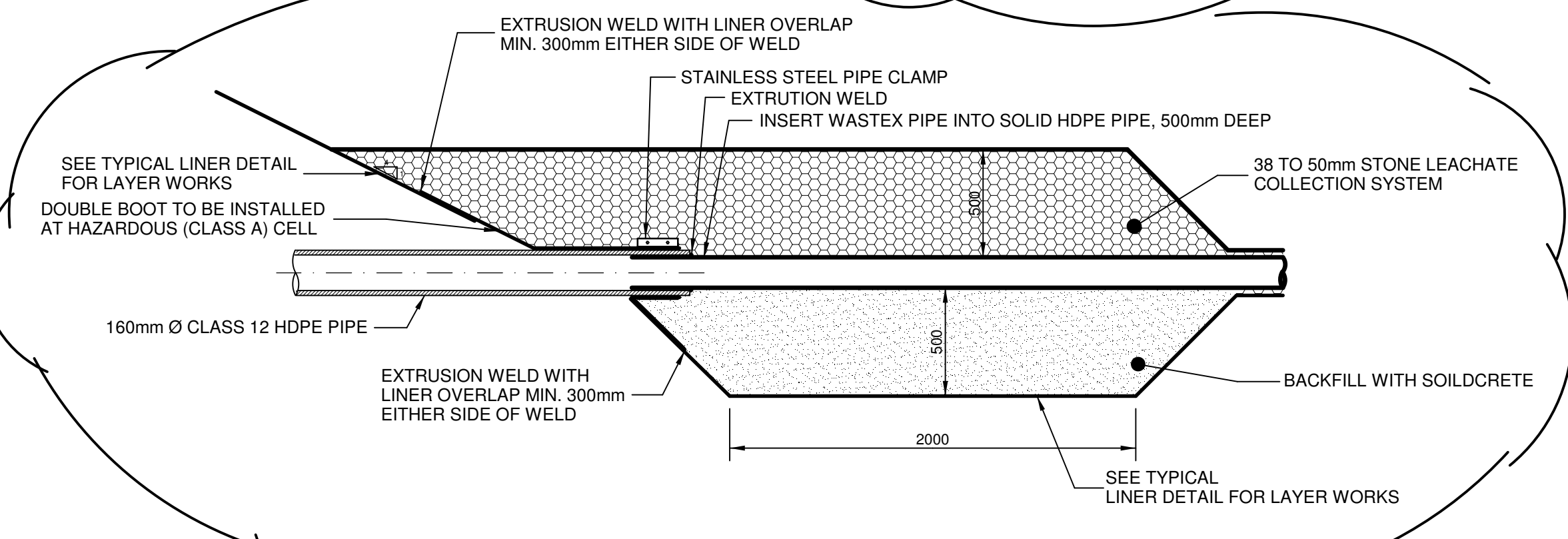

LEACHATE PIPE CELL OUTLET
NOT TO SCALE

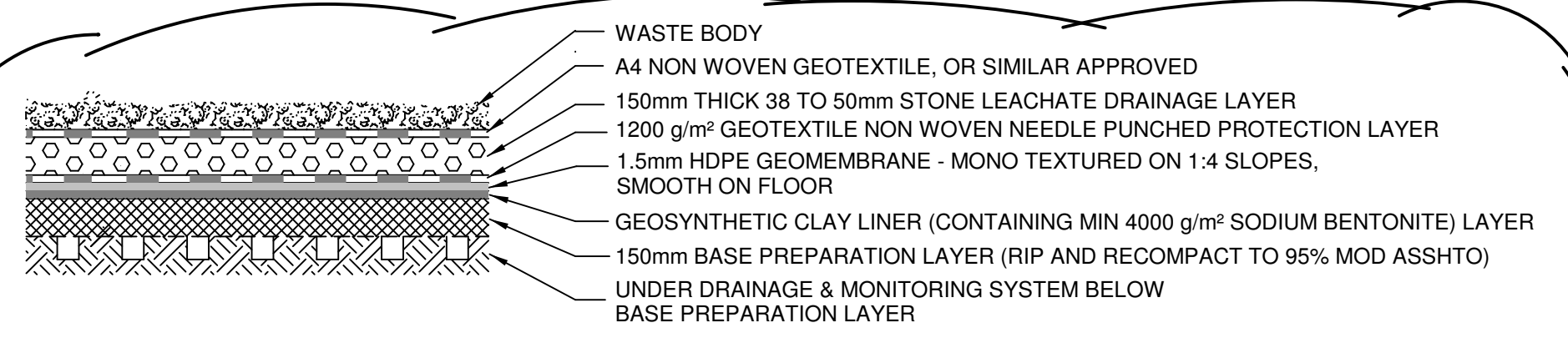

PROPOSED CELL LINING DETAIL

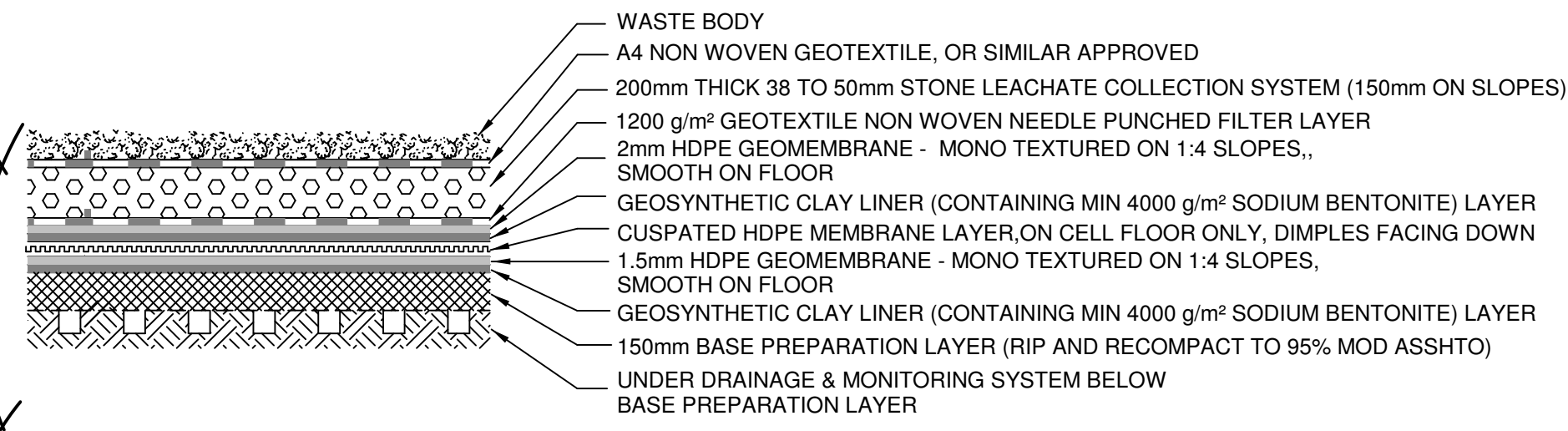

PROPOSED HAZARDOUS LINING DETAIL

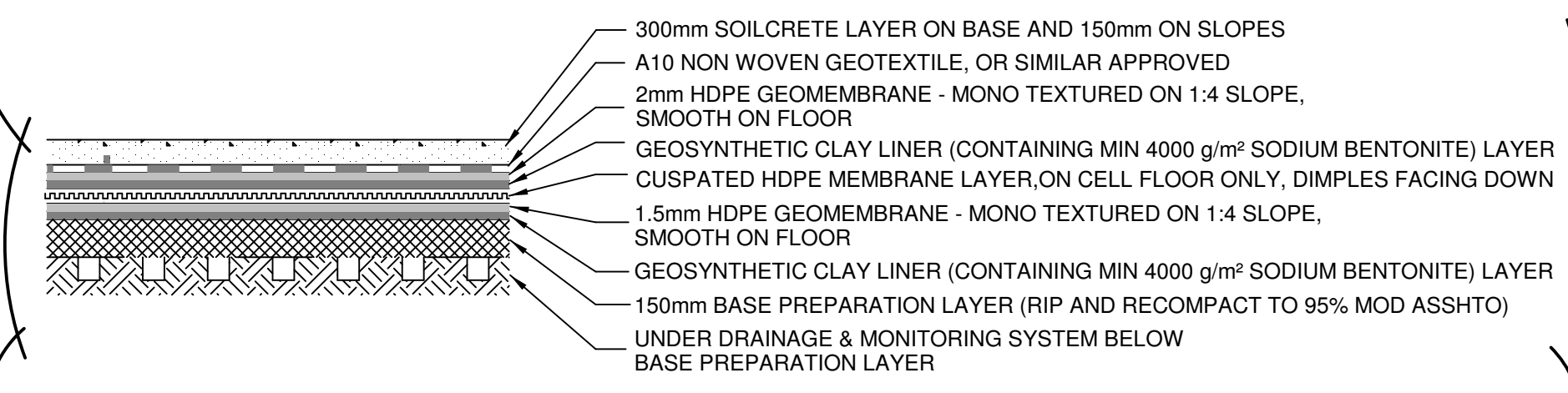

PROPOSED DAM LINING DETAIL - POLLUTION CONTROL

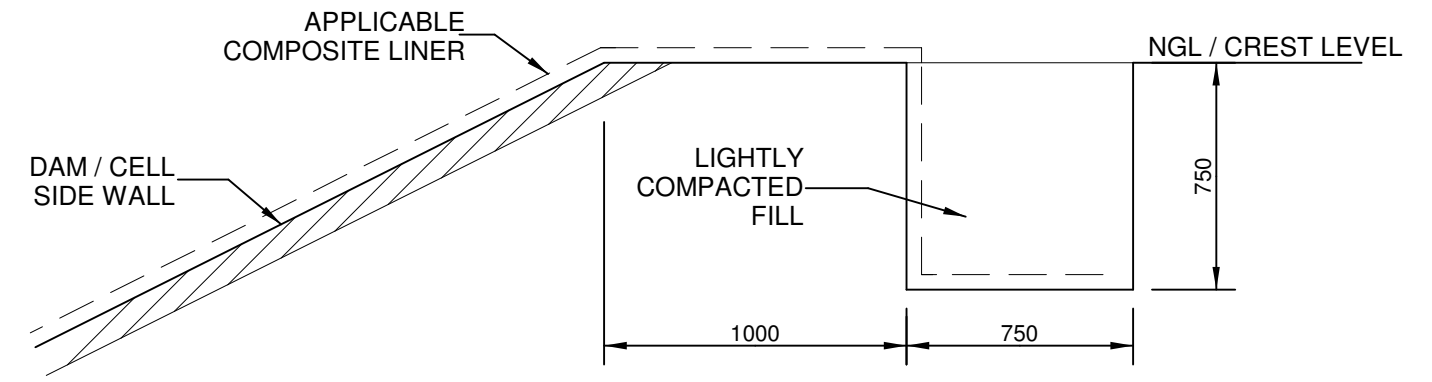

TYPICAL ANCHOR TRENCH DETAIL
SCALE 1:25

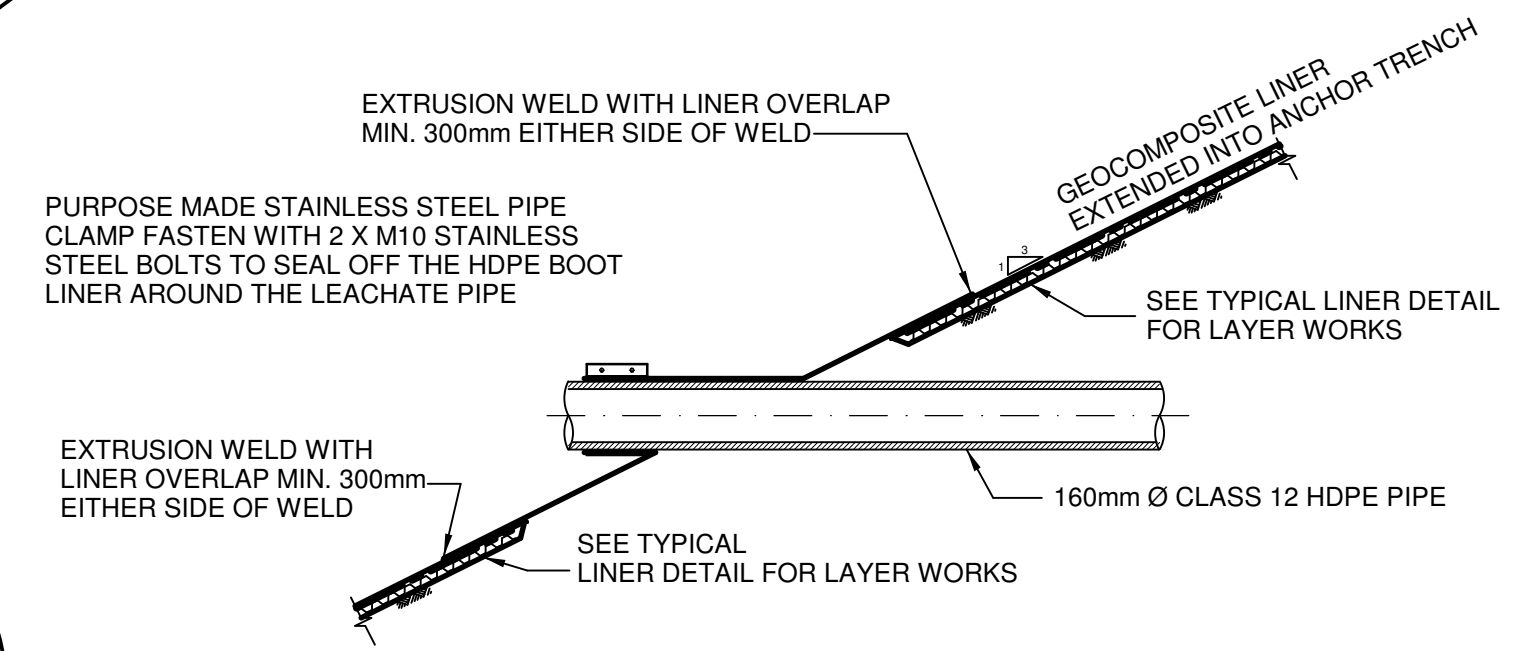

INLET PIPE INTO LEACHATE COLLECTION DAM
NOT TO SCALE

EcoCivil retains the copyright in all intellectual property, including designs and/or documents prepared in terms of this appointment for the project covered by the appointment. The client may use the designs and/or documents for the sole purpose of their intended use on this project only subject to payment for the design having been received. Use for any other purpose, whether or not the design and/or documents have been paid for constitutes an infringement of copyright, and all rights are reserved.

All dimensions to be checked on site before any work is put in hand. Refer any discrepancies to the engineer.
Copyright reserved

DATE	REVISION	BY
17/05/2019	4	DRAINAGE DETAILS ADDED
10/05/2019	3	LEACHATE TANK ADDED
17/01/2019	2	LINER DETAILS UPDATED

EcoCivil
Consulting Engineers

1385 LAWSON AVENUE
WAVERLEY, 0186
TEL: +27 (0)82 774 4412
pieterdc@eccivil.co.za

INTERWASTE
ENVIRONMENTAL SOLUTIONS

2 BRAMMER STREET
INDUSTRIES EAST
GERMISTON SOUTH
+27 11 323 7300
info@interwaste.co.za

ENGINEER	DATE		
CLIENT	DATE		
DESIGNED	DRAWN	TRACED	APPROVED
PDC	PDC		

GARDEN ROUTE DISTRICT MUNICIPALITY

GARDEN ROUTE WASTE MANAGEMENT FACILITY

DRAWING DESCRIPTION

GENERAL DETAILS

SCALE: 1:5000 DATE: NOV 2018

DRAWING NUMBER: 18-0007-104 REVISION: 4

CLIENT'S DRAWING NUMBER

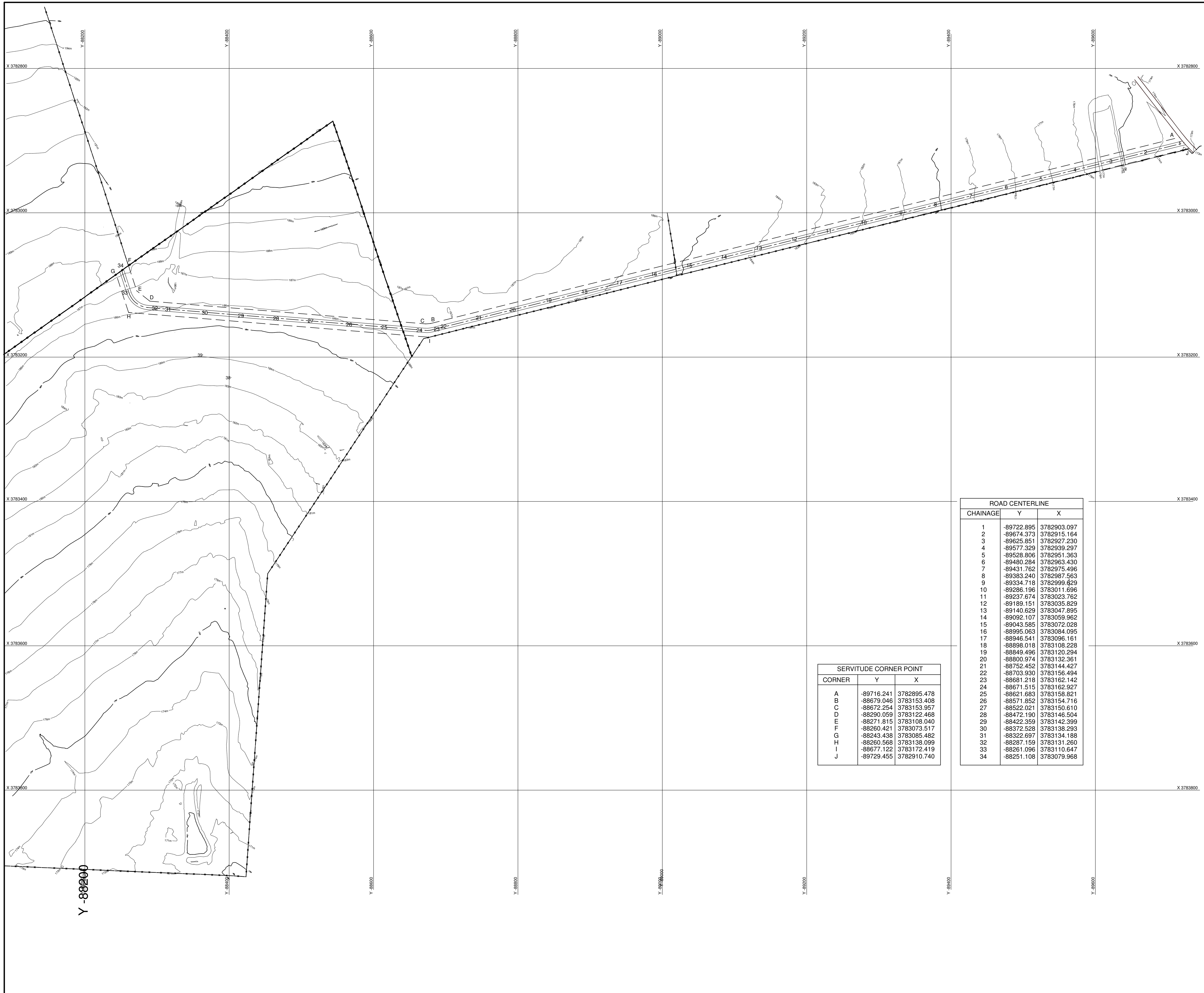

SERVITUDE CORNER POINT		
CORNER	Y	X
A	-89716.241	3782895.478
B	-88679.046	3783153.408
C	-88672.254	3783153.957
D	-88290.059	3783122.468
E	-88271.815	3783108.040
F	-88260.421	3783073.517
G	-88243.438	3783085.482
H	-88260.568	3783138.099
I	-88677.122	3783172.419
J	-89729.455	3782910.740

ROAD CENTERLINE		
CHAINAGE	Y	X
1	-89722.895	3782903.097
2	-89674.373	3782915.164
3	-89625.851	3782927.230
4	-89577.329	3782939.297
5	-89528.806	3782951.363
6	-89480.284	3782963.430
7	-89431.762	3782975.496
8	-89383.240	3782987.563
9	-89334.718	3782999.629
10	-89286.196	3783011.696
11	-89237.674	3783023.762
12	-89189.151	3783035.829
13	-89140.629	3783047.895
14	-89092.107	3783059.962
15	-89043.585	3783072.028
16	-88995.063	3783084.095
17	-88946.541	3783096.161
18	-88898.018	3783108.228
19	-88849.496	3783120.294
20	-88800.974	3783132.361
21	-88752.452	3783144.427
22	-88703.930	3783156.494
23	-88655.408	3783168.560
24	-88606.886	3783180.627
25	-88558.364	3783192.693
26	-88509.842	3783204.760
27	-88461.320	3783216.826
28	-88412.798	3783228.893
29	-88364.276	3783240.959
30	-88315.754	3783253.026
31	-88267.232	3783265.092
32	-88218.710	3783277.158
33	-88170.188	3783289.225
34	-88121.666	3783301.291

EcoCivil retains the copyright in all intellectual property, including designs and/or documents prepared in terms of this appointment for the project covered by the appointment. The client may use the designs and/or documents for the sole purpose of their intended use on this project only subject to payment for the design having been received. Use for any other purpose, whether or not the design and/or documents have been paid for constitutes an infringement of copyright, and all rights are reserved.

All dimensions to be checked on site before any work is put in hand. Refer any discrepancies to the engineer. Copyright reserved

10/05/2019	1	COORDINATES UPDATED	PDC
DATE	REVISION	BY	



1365 LAWSON AVENUE
WAVERLEY, 0186
TEL: +27 (0)82 774 4412
FAX: +27 (0)86 460 7150

ENGINEER _____ DATE _____

CLIENT _____ DATE _____

DESIGNED	DRAWN	TRACED	APPROVED
PDC	PDC		

CLIENT
GARDEN ROUTE DISTRICT MUNICIPALITY

PROJECT
GARDEN ROUTE WASTE MANAGEMENT FACILITY

DRAWING DESCRIPTION
ENTRANCE ROAD SERVITUDE

SCALE 1:2500 DATE MAY 2019

DRAWING NUMBER 18-0007-202 REVISION 1

CLIENT'S DRAWING NUMBER